

NAPL Source Zone Remediation utilizing Supersaturated Water Injection A Gas inFusion Technology



BUILDING A TALENT TRUST





Need for Enhanced Recovery

“Under many conditions, it is likely that LNAPL-sourced dissolved and vapor plumes will be present for decades to centuries unless treatment options improve significantly.”

API Publication 4715, September 2002



Supersaturated Water Injection (SWI)

- LNAPL and DNAPL recovery enhancement system for trapped and immobile NAPL mass
- Uses carbon dioxide to strip volatile NAPL component for capture in the unsaturated zone
- Mobilizes liquid NAPL trapped in aquifer matrix for recovery



Physical mechanisms of SWI

- Production and injection of CO₂ supersaturated water
- Water distribution mechanism efficiently sweeps target area resulting in even gas distribution
- Gas bubbles form, NAPL spreads over the gas surface and is volatilized into the bubble
- Nucleated bubbles push NAPL upward



Introduction to gPRO™ HP

- Gas inFusion was invented by inVentures Technologies inc. (iTi)
- Patented technology that allows for the efficient continuous transfer of gas into water

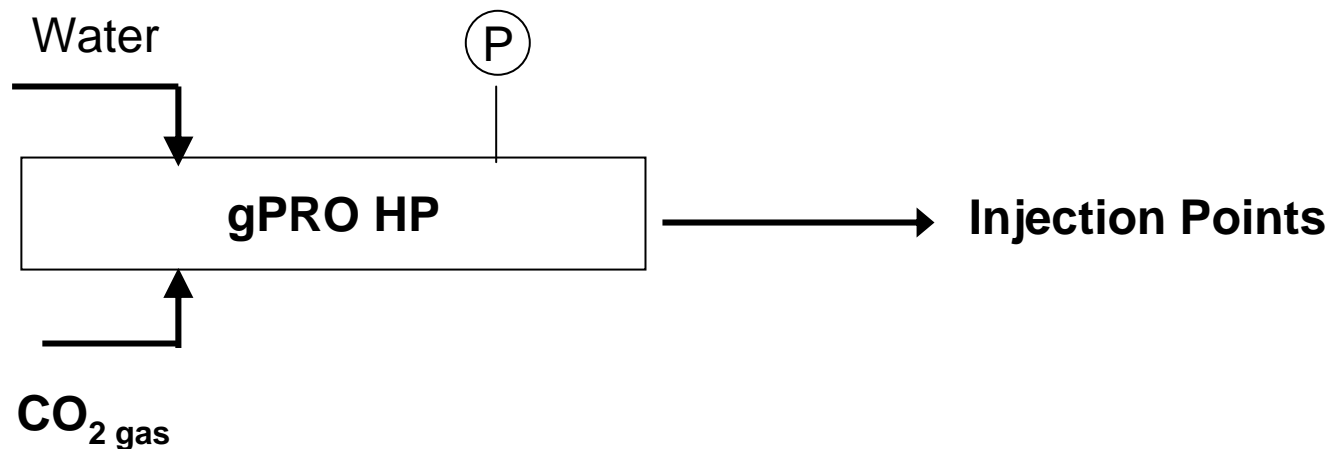



Introduction to gPRO™ HP

- Hydrophobic Micro Hollow Fibers provide surface area between water and gas for high mass transfer efficiency
- $P_{\text{gas}} = P_{\text{water}}$; Bubble-free gas transfer eliminates losses
- High dissolved gas concentrations are obtained

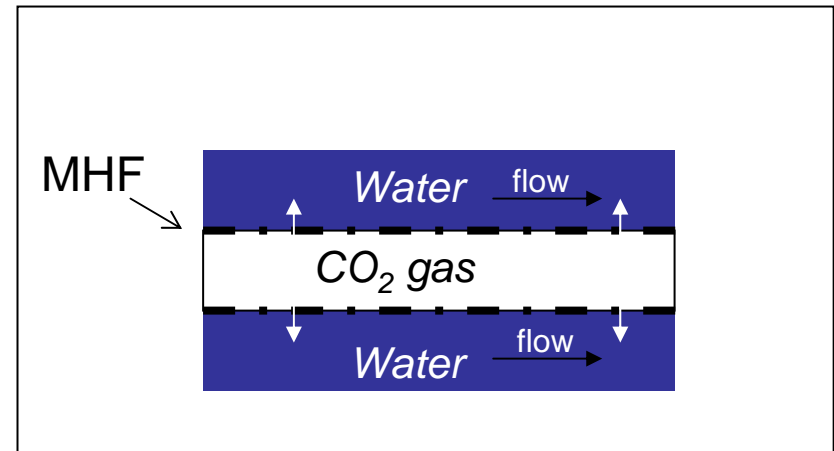
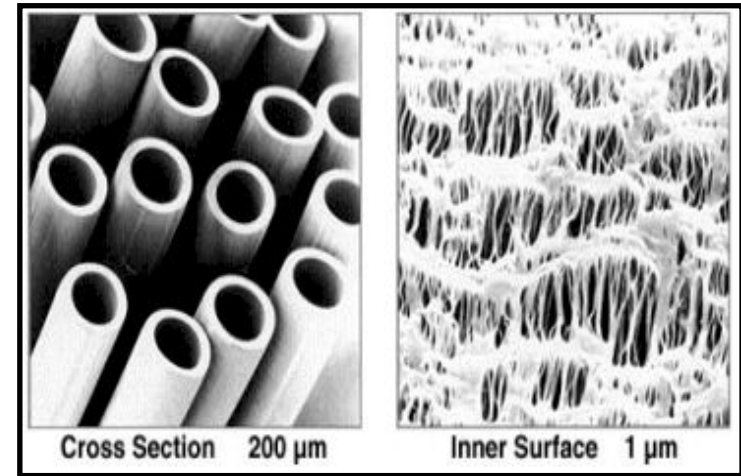

gPRO™ Mass Transfer Modules

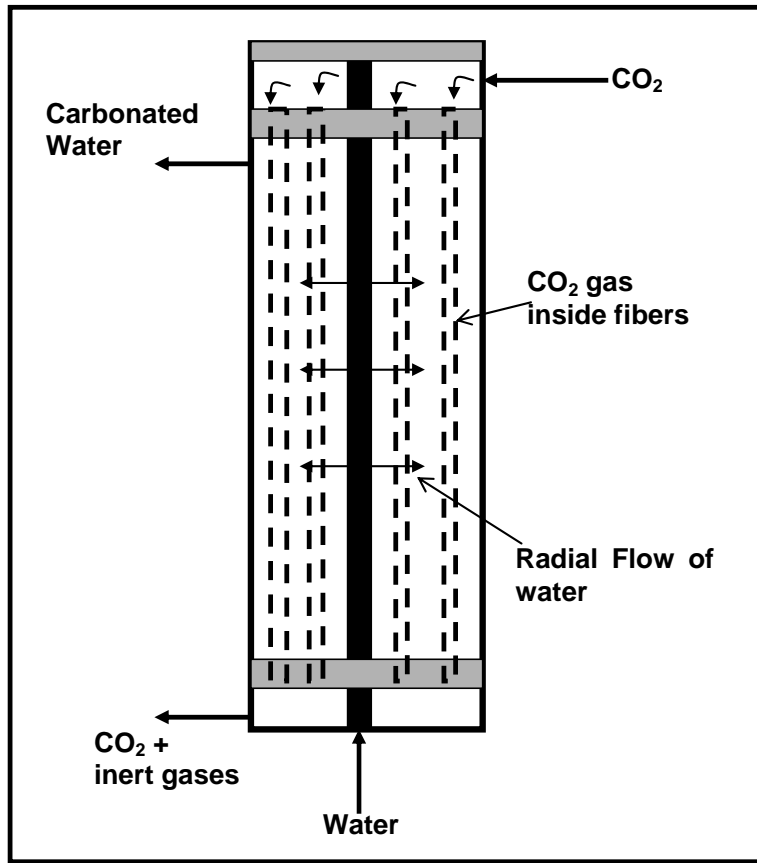

The gPRO™ mass transfer modules provide super efficient transfer of dissolved gases into liquids

For the SWI application the gPRO™ is transferring supersaturated levels of CO₂ into water



gPRO™ HP Gas inFusion System





Conceptual model for field trial

- Water is supersaturated with CO₂ in the gPRO™ HP System
- Supersaturated water is injected into the aquifer through injection points
- CO₂ bubbles nucleate at various points in the aquifer

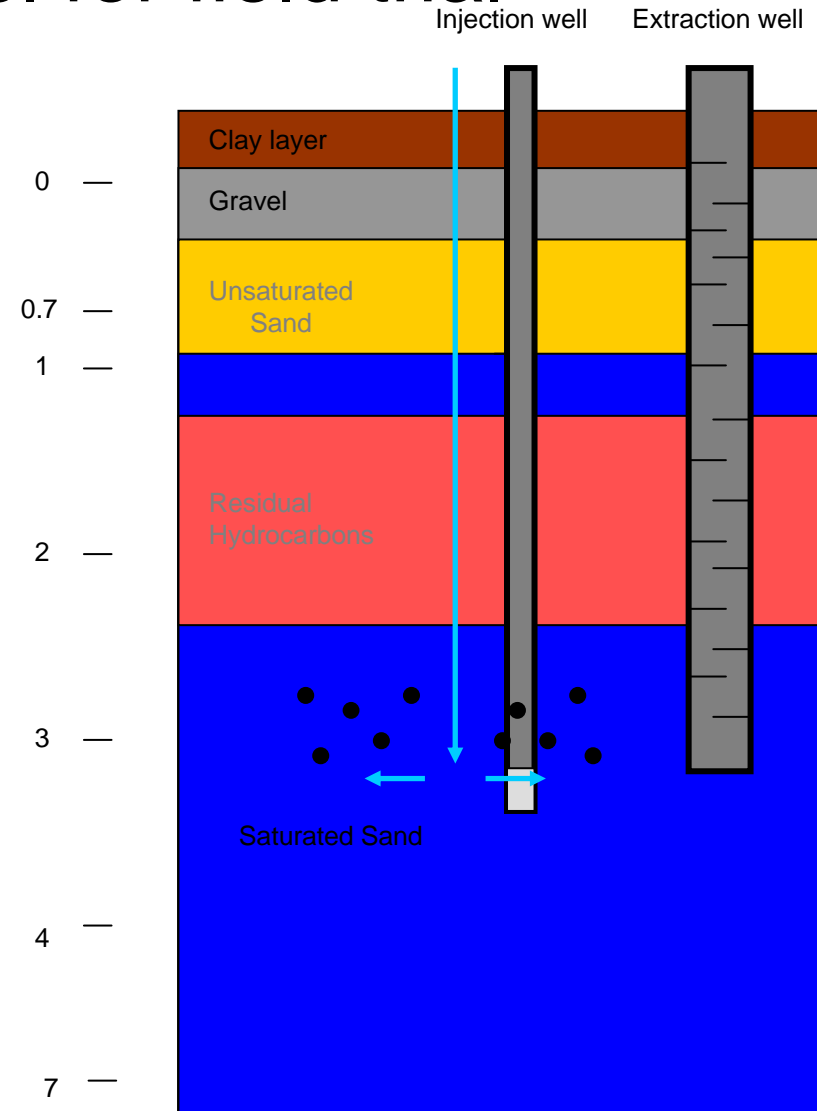



Conceptual model for field trial

- When the rising CO_2 bubbles contact hydrocarbons they cause volatilization of the hydrocarbons
- Groundwater and soil vapour (including CO_2 and volatilized hydrocarbons) are removed through dual phase extraction wells

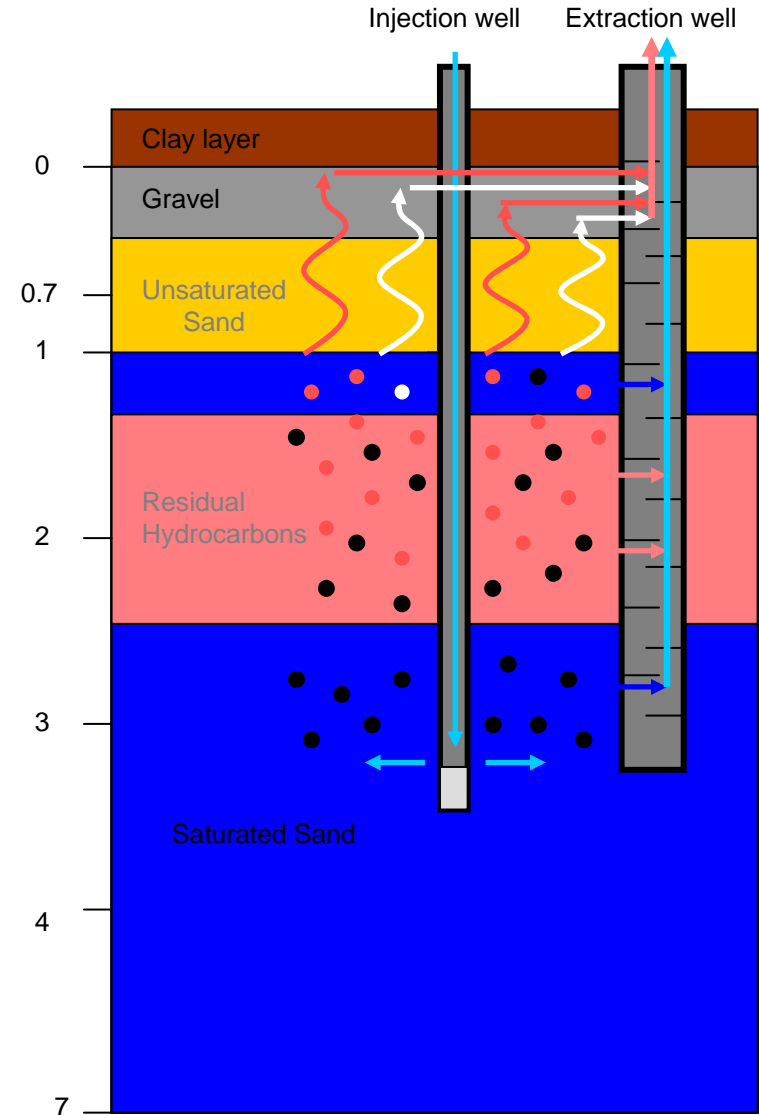



Direct pore-scale evidence - Volatilization

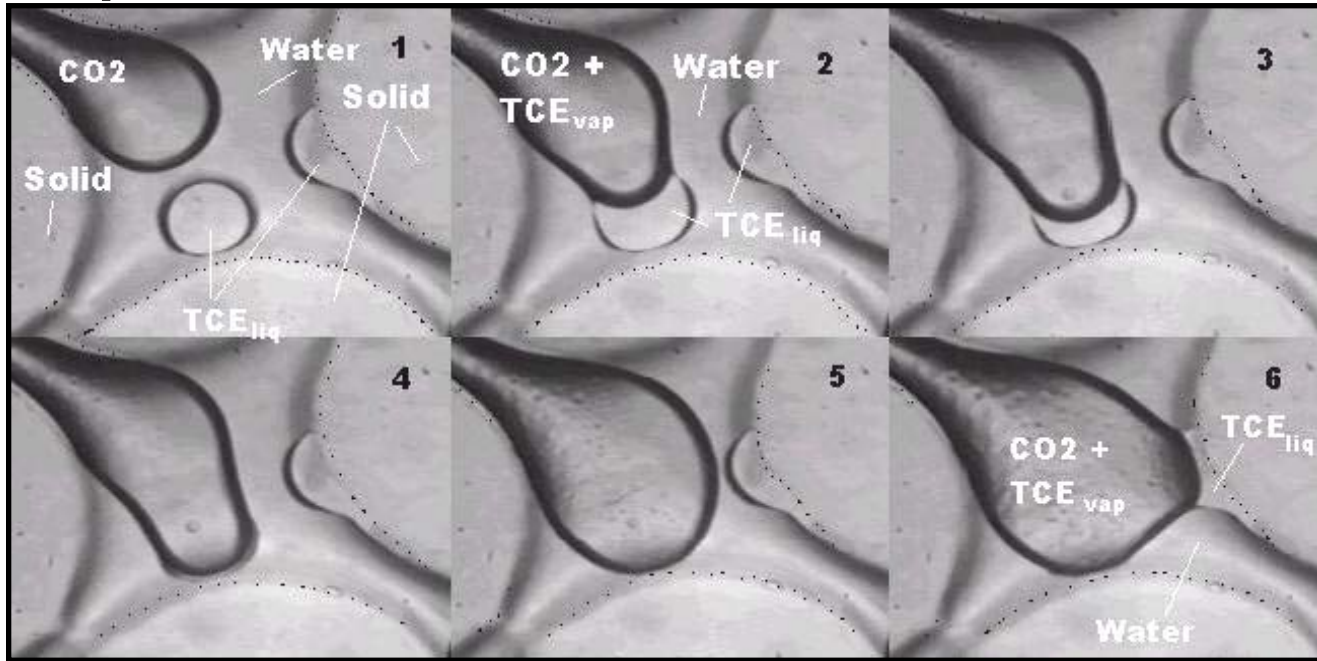

- A CO₂ bubble growing by mass transfer from the injected supersaturated aqueous phase
- Upon contact with the bubble, NAPL spontaneously spreads over bubble
- Volatile components of the NAPL are readily transferred into the bubble



Mobilization of NAPL ganglia for recovery

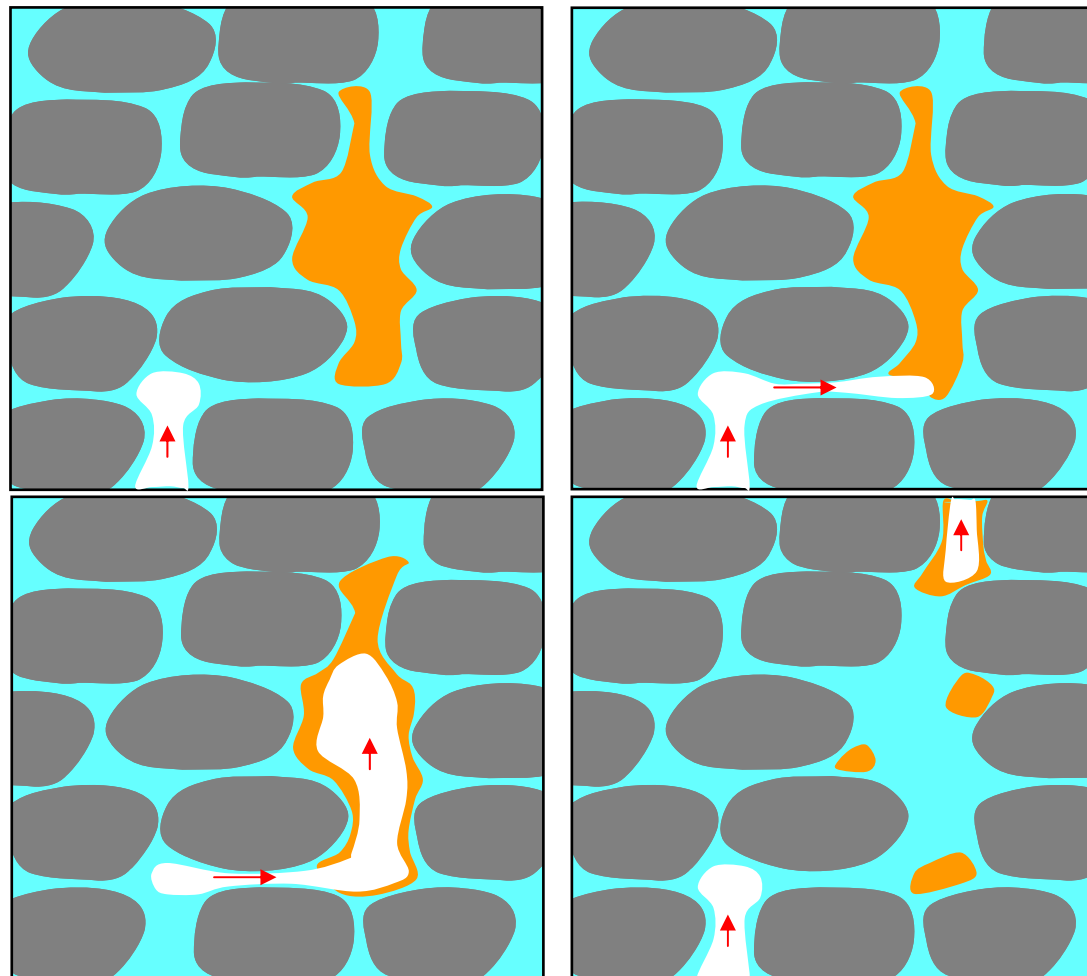

Conceptual demonstration of **nonvolatile** NAPL (Soltrol) recovery by SWI



Recovery by mobilization of NAPL ganglia

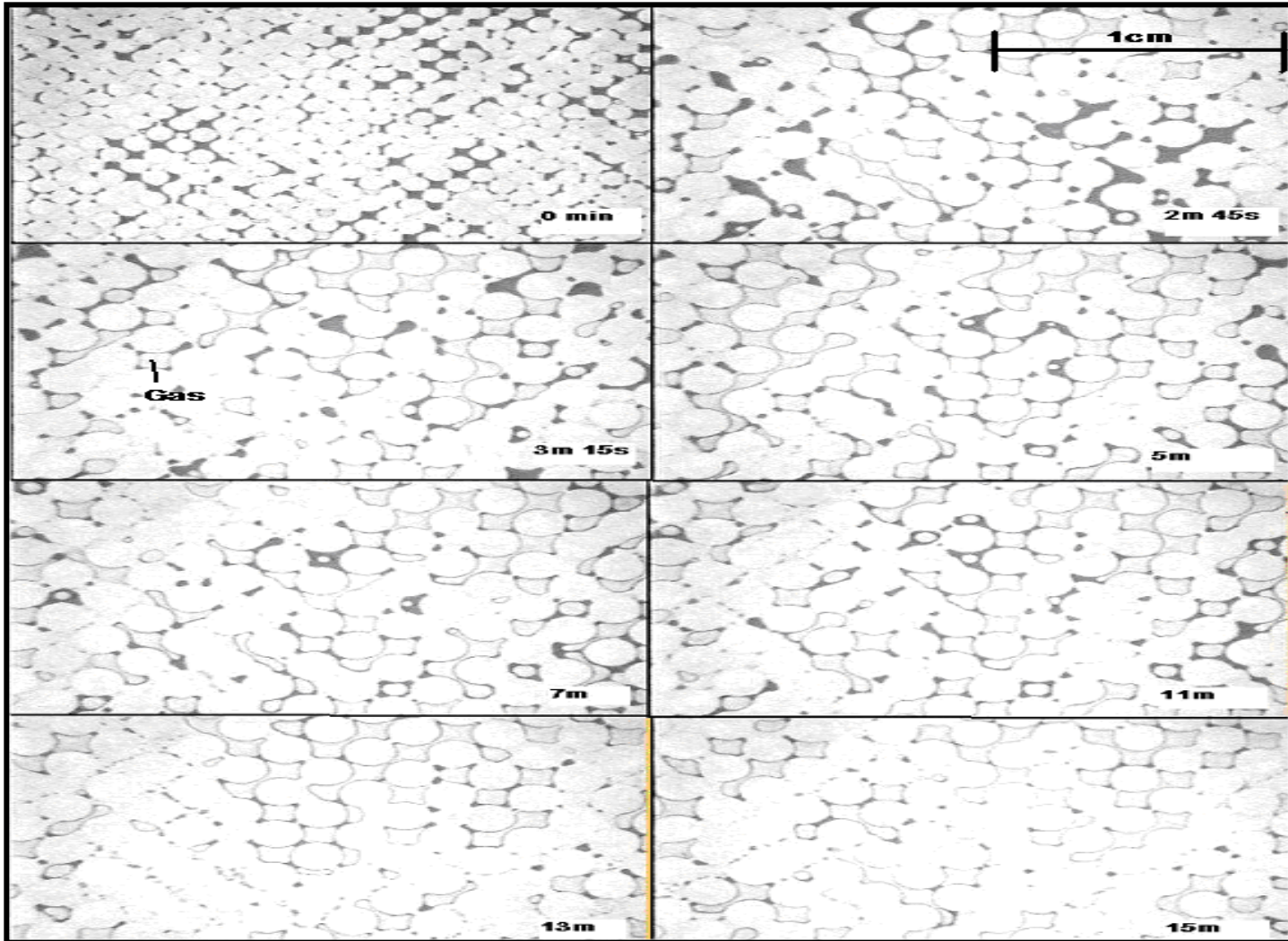

Actual demonstration of **nonvolatile** NAPL (Soltrol) recovery by SWI



Proof of concept in the lab: In situ gas saturation development and rate of gas evolution

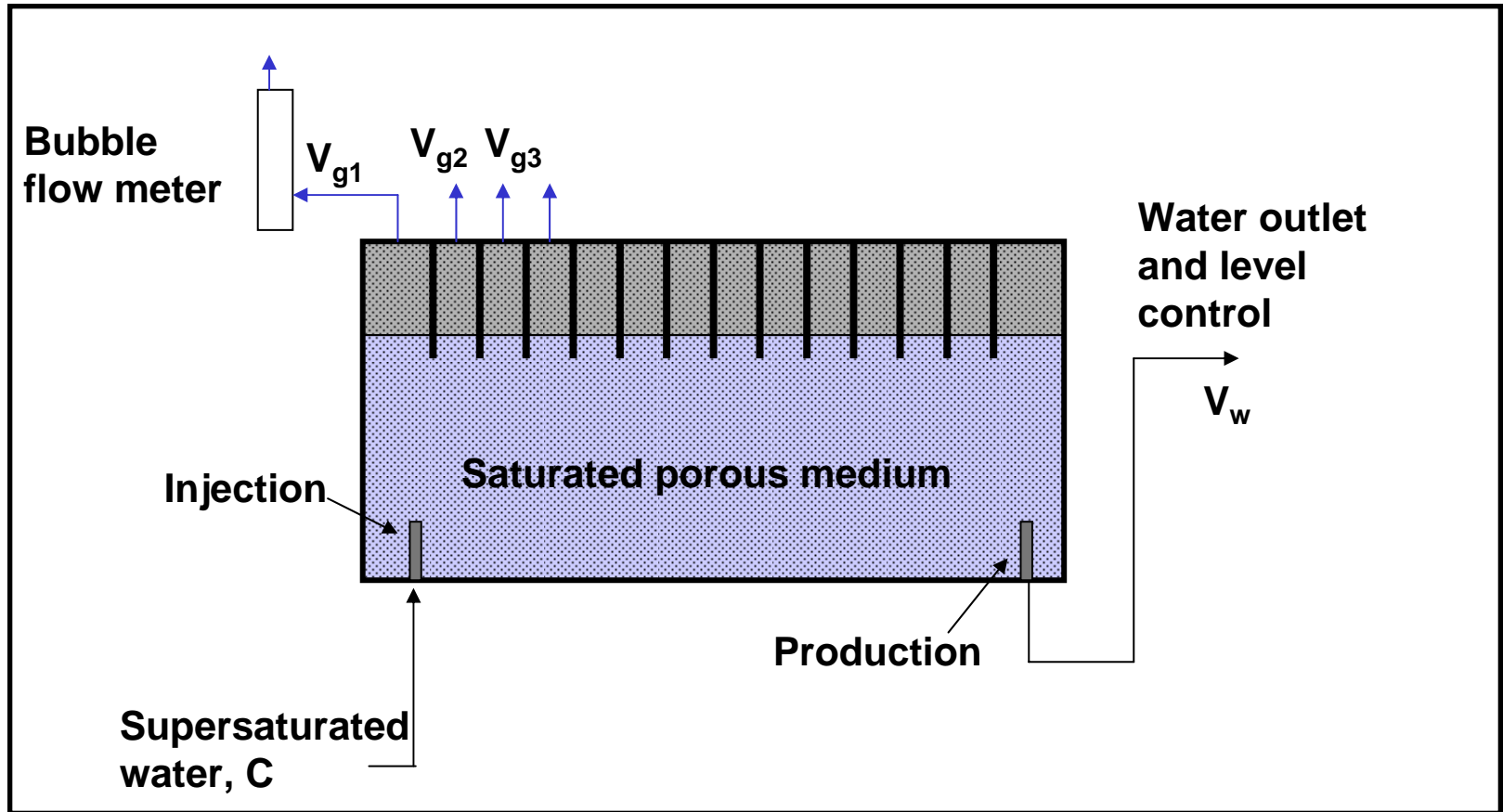



Gas evolution during SWI: Experiment

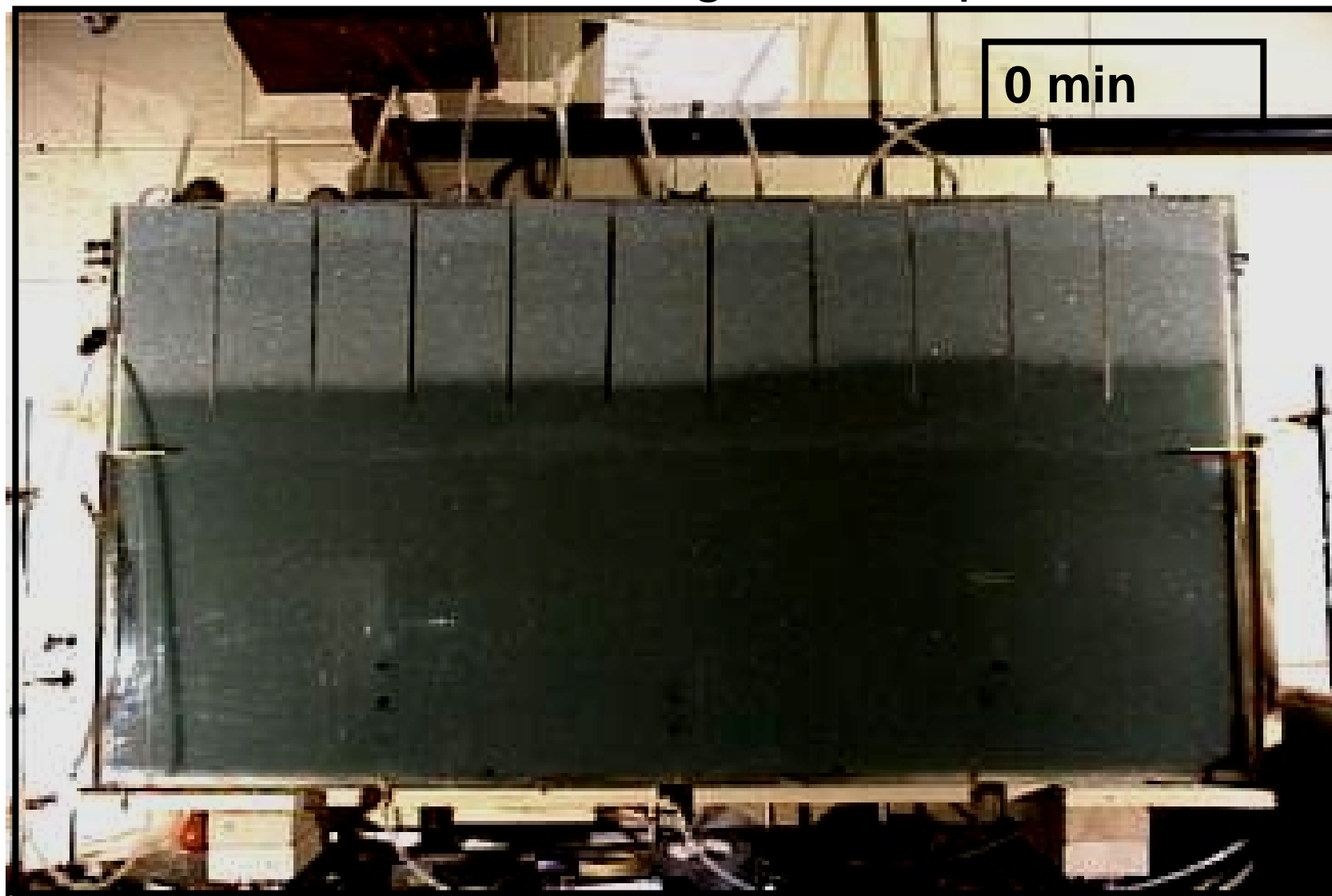



In situ gas evolution in the presence of impermeable barriers

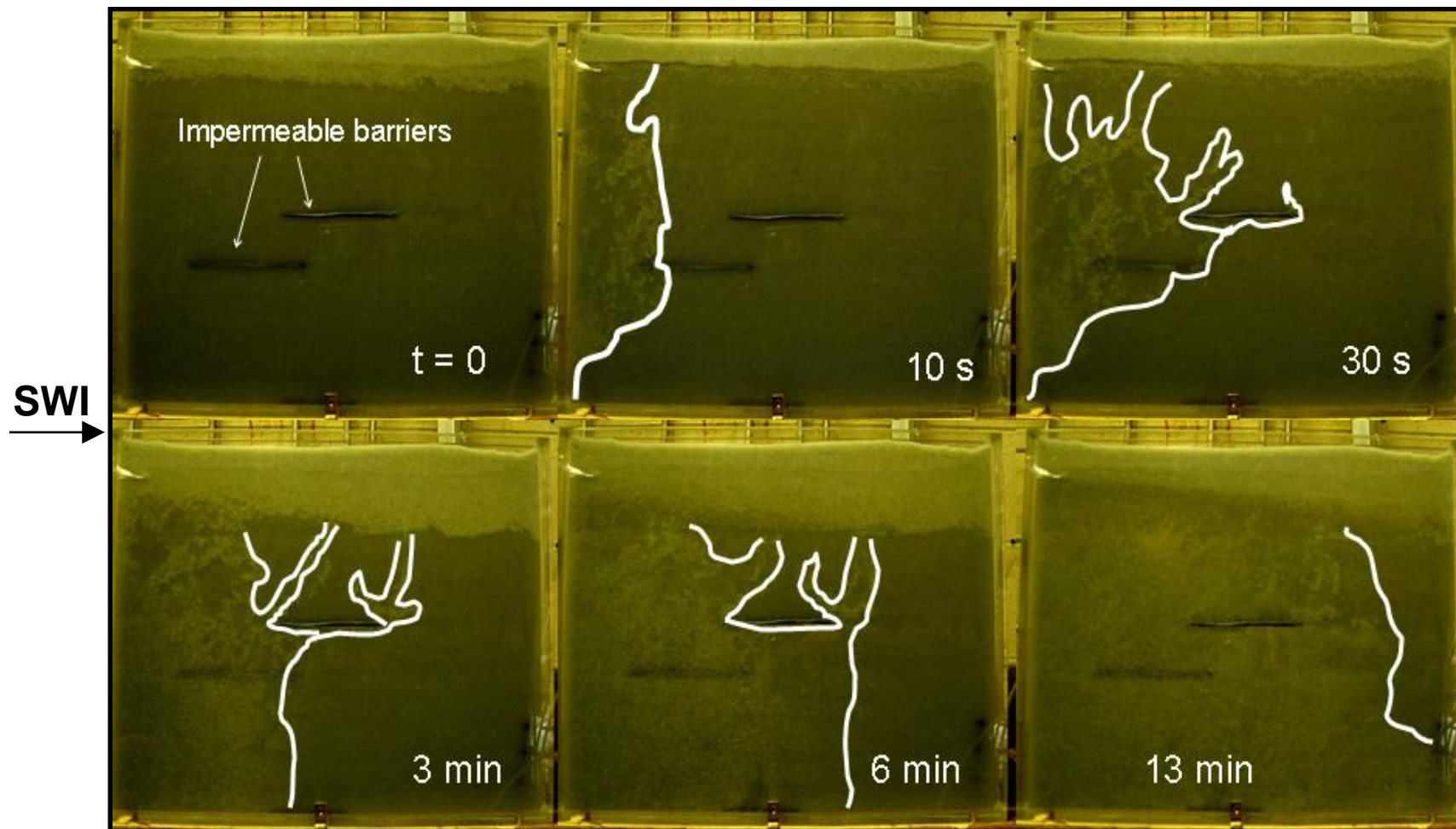



Recovery of residual hexane by SWI

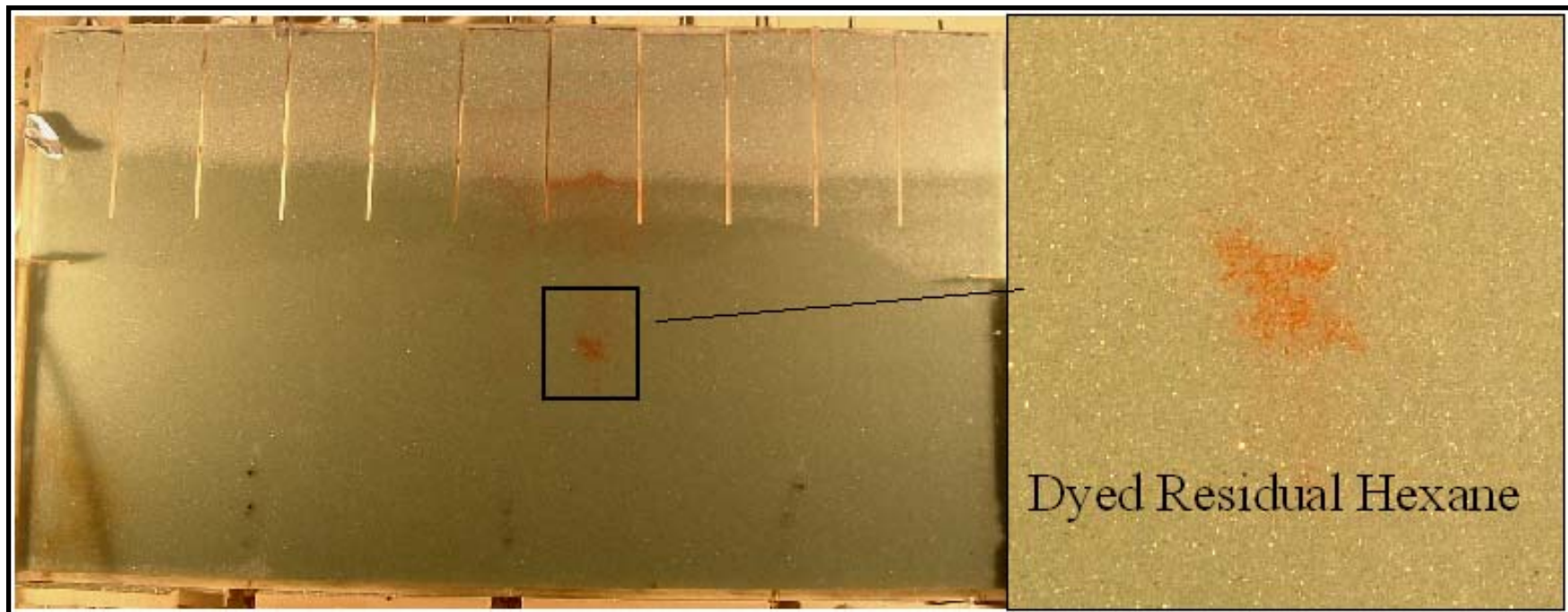

Recovered 100% of hexane in lab scale experiment in 65 minutes



Recovery of residual hexane by SWI

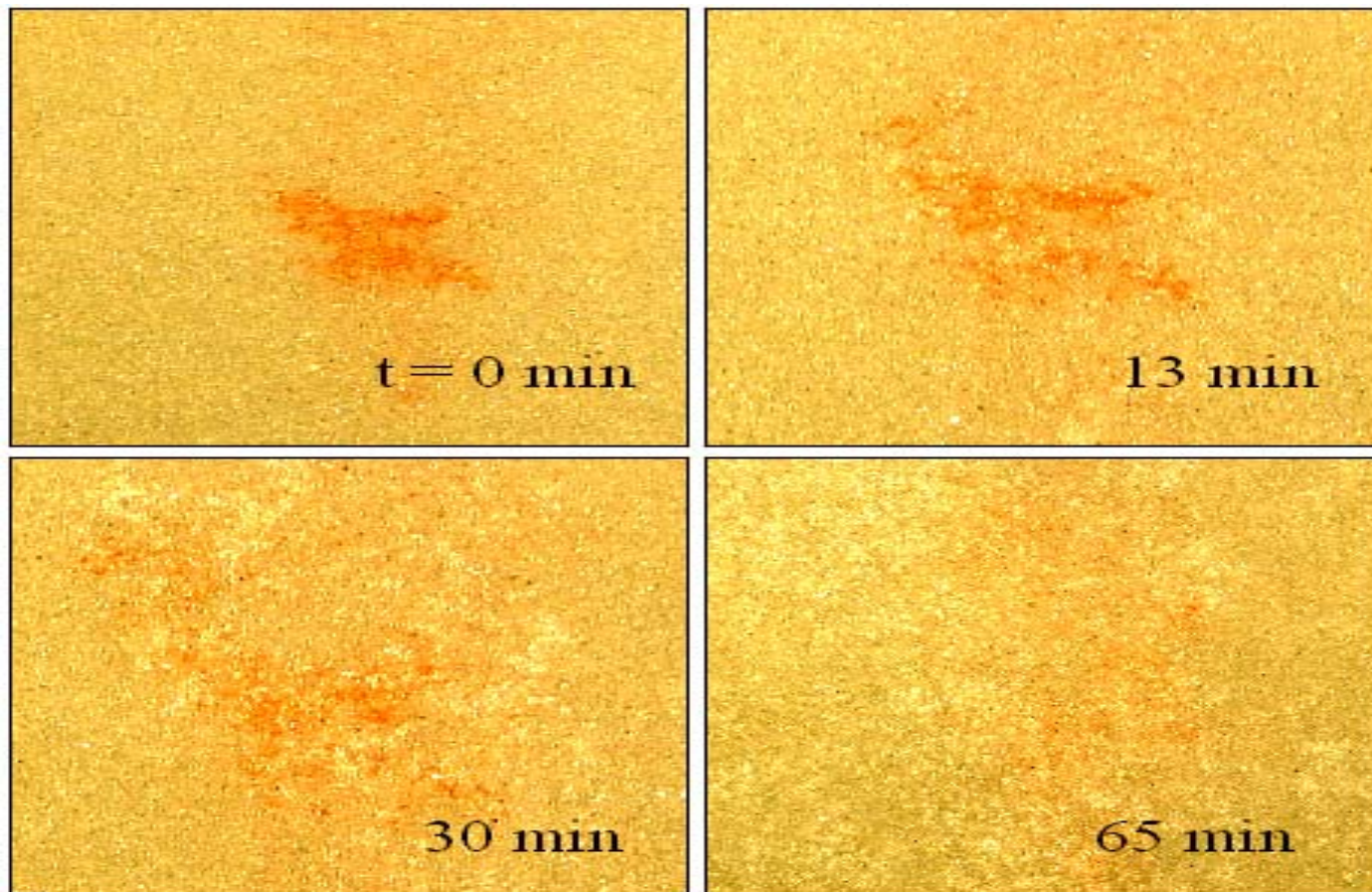

Volatile NAPL is removed by gas evolution



Proof of concept in the field

- 200 L of hydrocarbon (mixture of pentane, hexane and Soltrol) existing as residual NAPL in the saturated zone (enclosed cell in the sand pit at Borden)



Field Experimental Processes

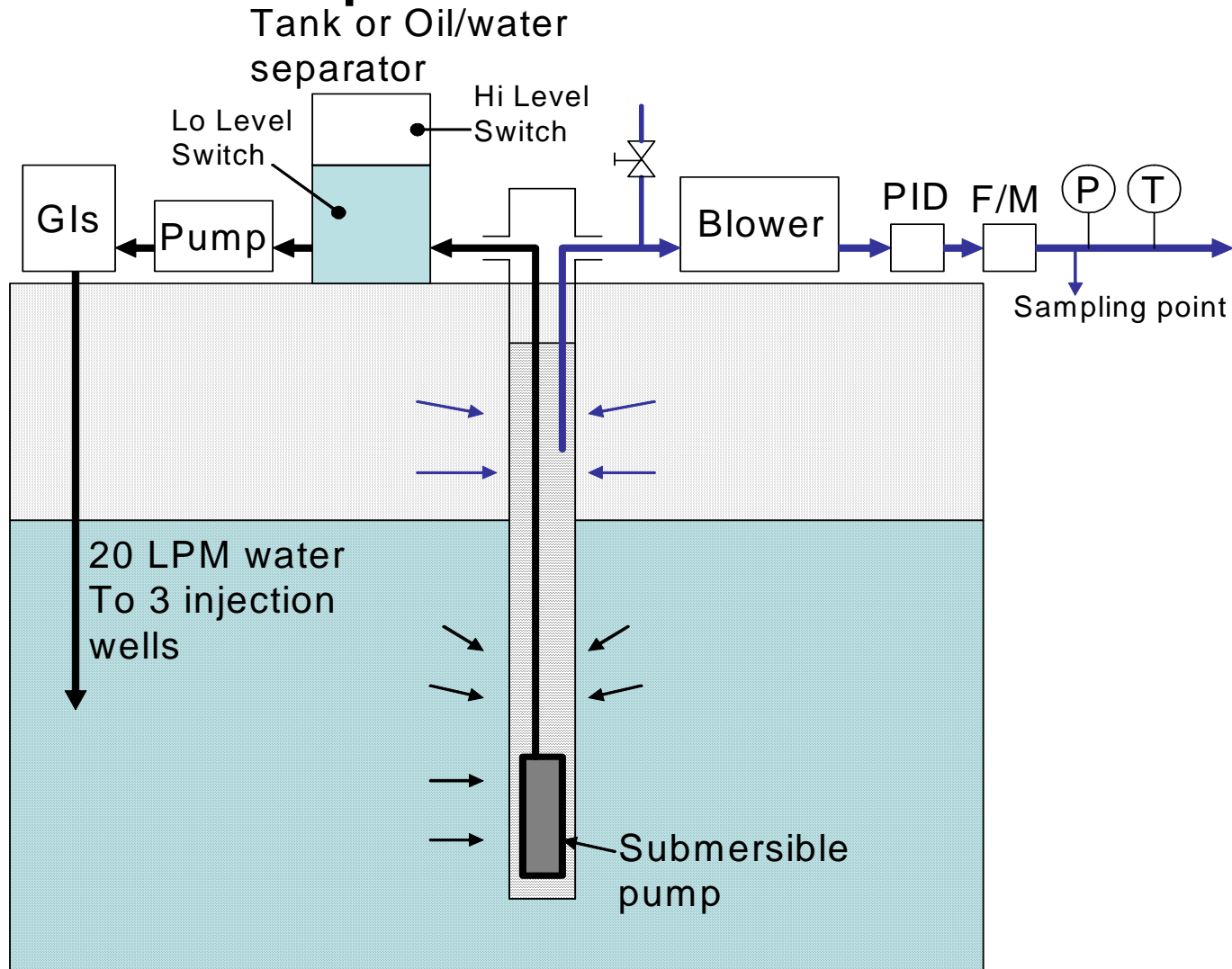



Field Experiment Cell

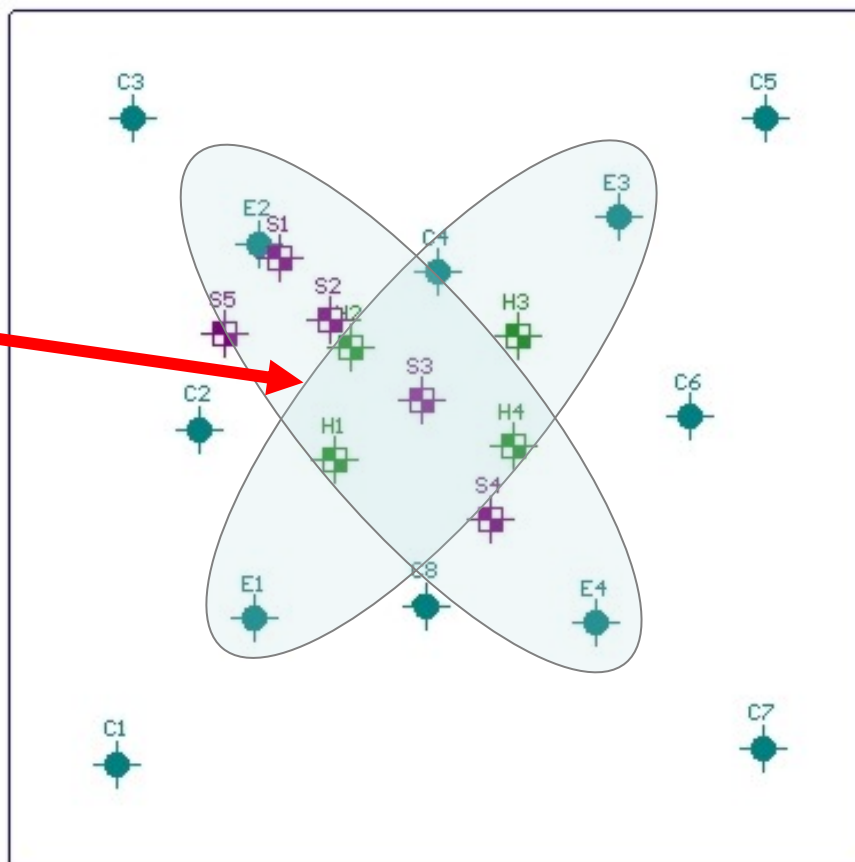

NAPL residual



Field Experiment

1st round of injection

Carbonated water injection and extraction (3 triangle patterns used)

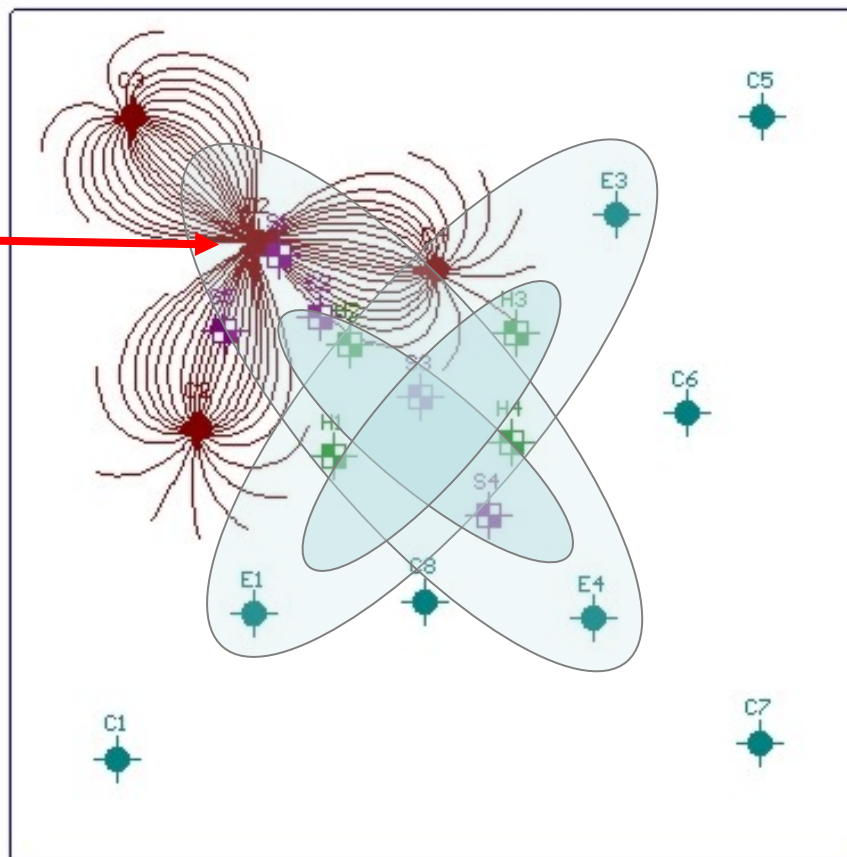



Field Experiment- 2nd phase of injection

Carbonated water injection and extraction (center injection with sequential 4 quadrant extraction)

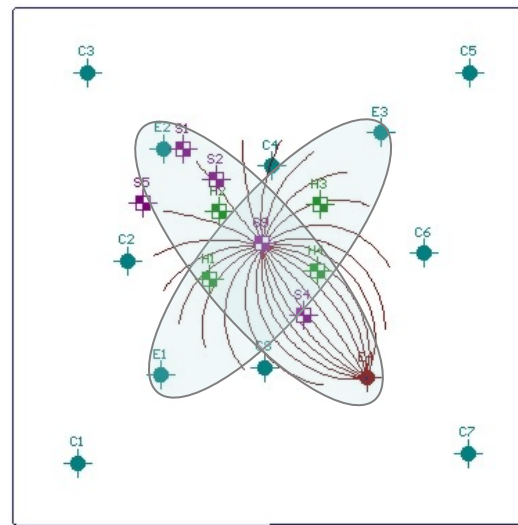
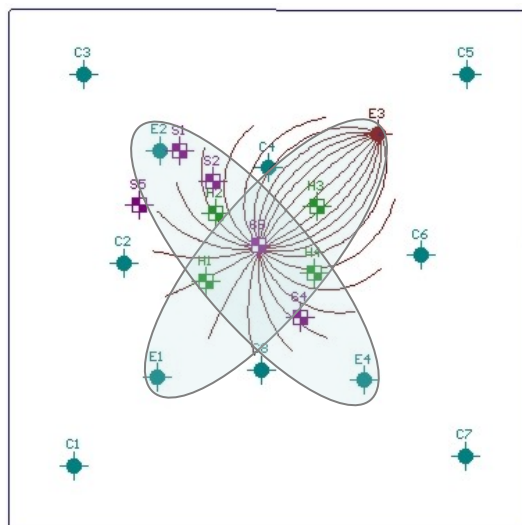
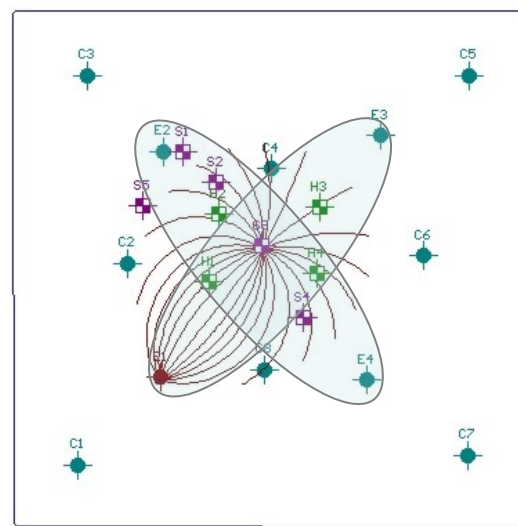
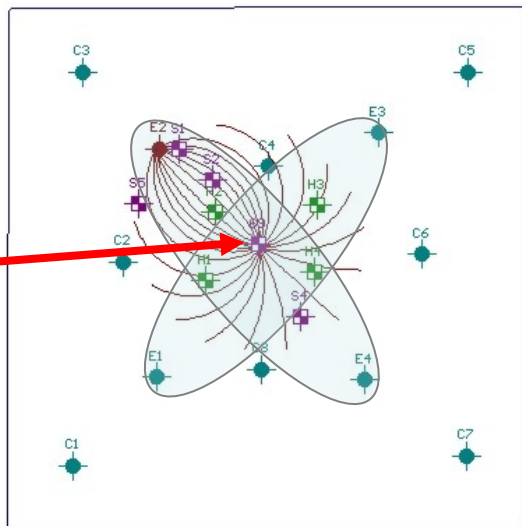



NAPL Mass Removal

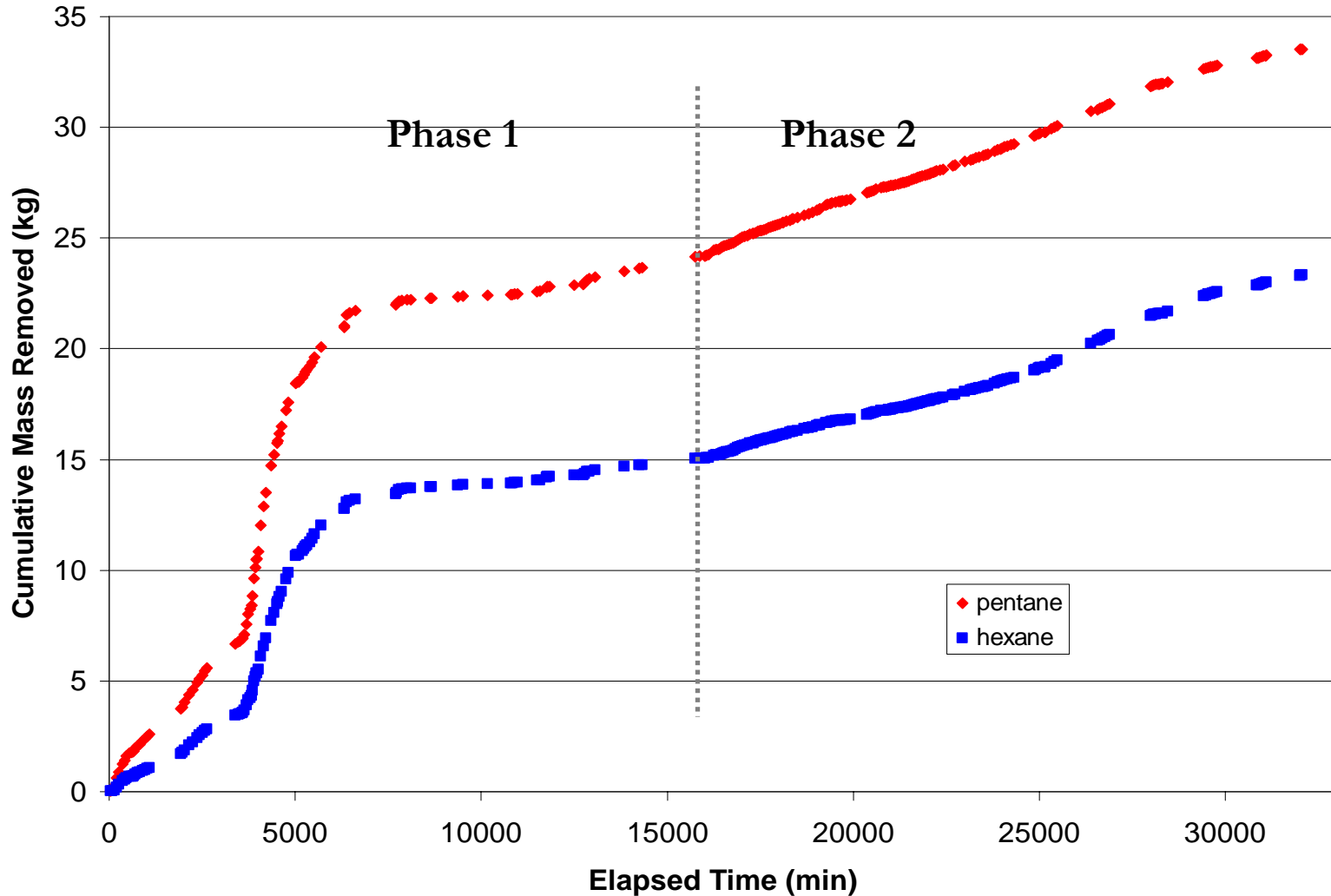



NAPL Mass Removal

	Pentane		Hexane		Total	
	Mass (kg)	%	Mass (kg)	%	Mass (kg)	%
Phase I	24.2	57	15.1	35	39.3	44
Phase II	9.3	20	8.3	18	17.6	20
Total	33.5	77	23.3	53	56.8	64



Soil Sampling

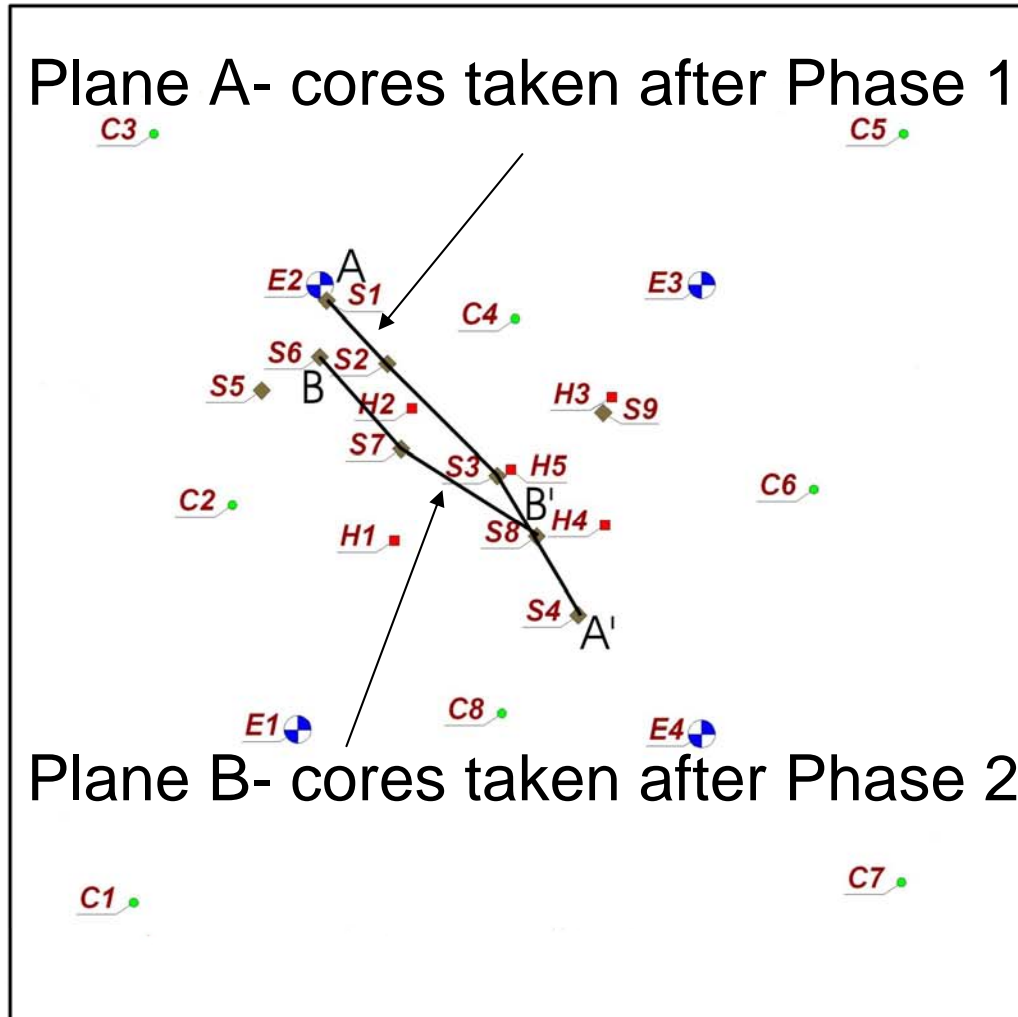

- Hydrocarbon Injection Wells
- ⊕ Extraction Wells
- CO₂ Injection Wells
- ◆ Soil Cores





Core Sampling- NAPL Concentration

Plane A (after 1st phase)

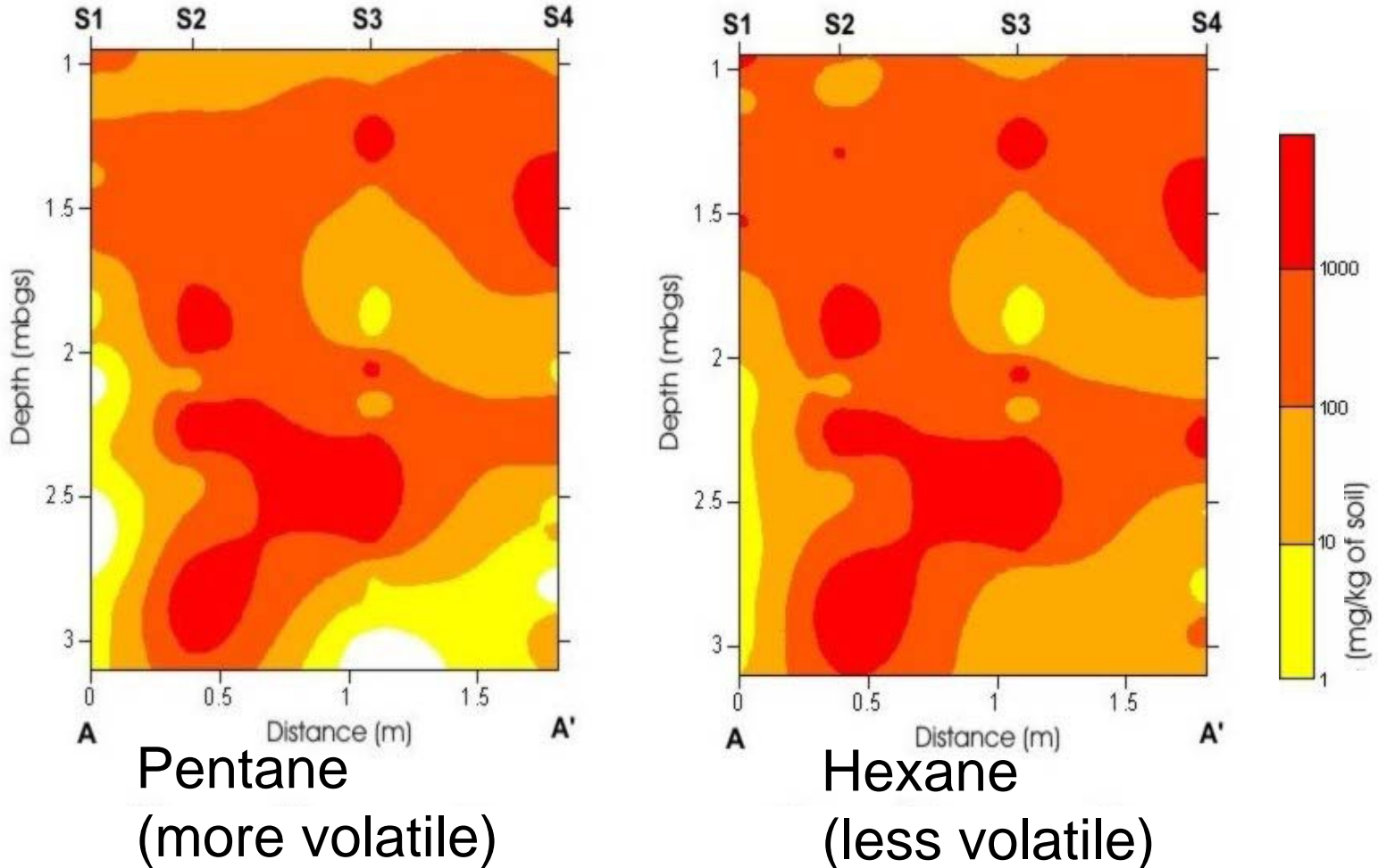



Core Sampling- NAPL Concentration

Plane B (after 2nd phase)

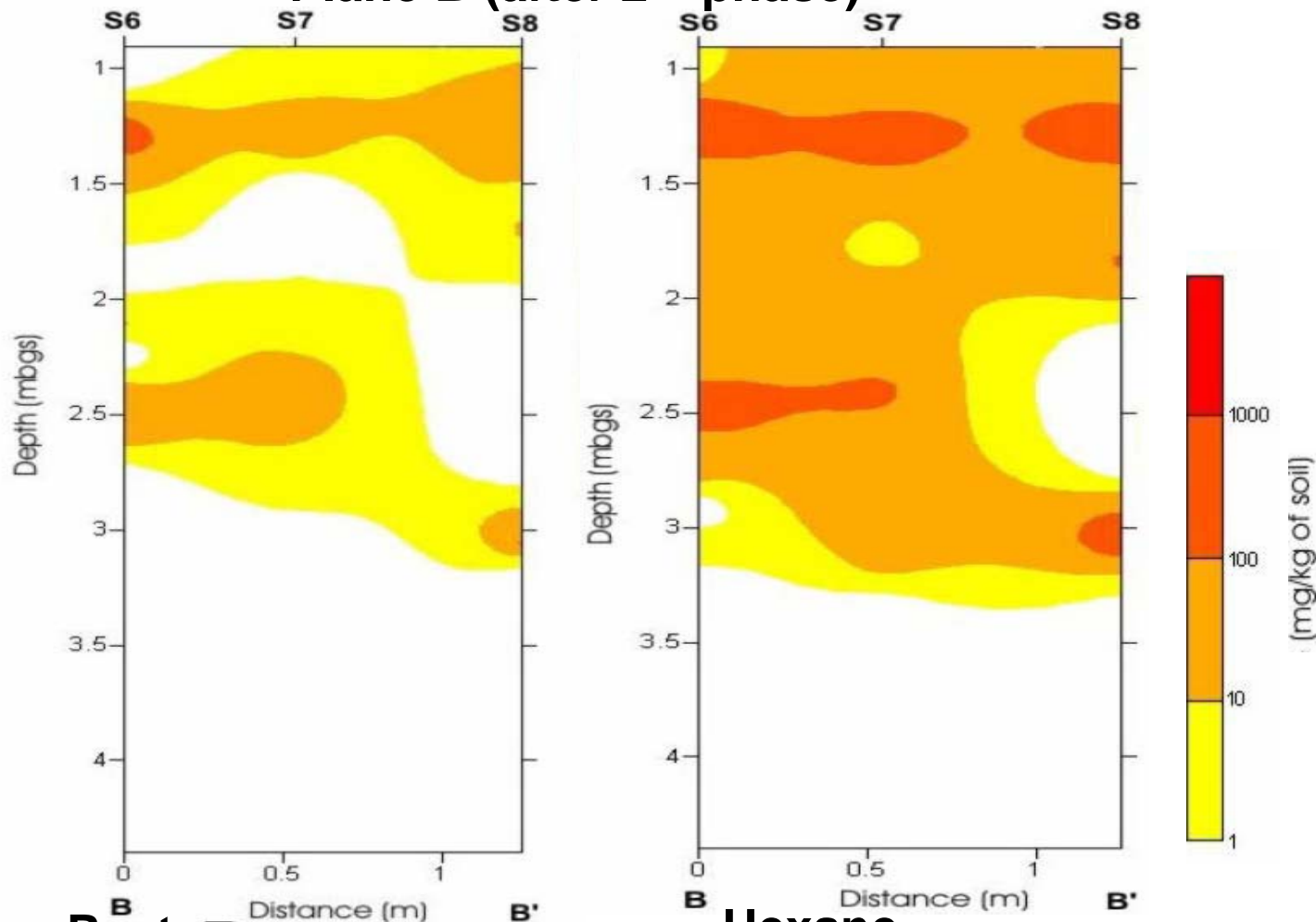

Pentane
(more volatile)

Hexane
(less volatile)



Demonstration Conclusions

- 77 % of the Pentane and 53 % of the Hexane were recovered out of the original 89 kg by volatilization alone
- Soil samples showed mobilization of a majority of the NAPL towards the water table indicating it would be available for liquid phase recovery



Summary

- SWI represents a significant improvement over unassisted dual phase extraction:
 - Greater zone of influence, recovery rate and percentage removed
 - NAPL trapped in pore space below the water table can be mobilized upwards by gas bubbles
 - Cost effective feasible implementation compatible with dual phase extraction



Next Steps

- Demonstrate at a real site with a NAPL problem
- Concentrate on the design of the well injection system to refine delivery of CO₂ saturated water
- Understand and quantify the advantages of SWI NAPL Recovery in terms of - Time – Feasibility - \$'s